



1 ton Electric Chain Hoist 1 Speed 208~240V / 440~480V 3ph 60HZ

Características Esenciales

- 3 Años de Garantía, Partes y Servicios Disponibles en América

1 ton Electric Chain Hoist 1 Speed 208~240V / 440~480V 3ø 60HZ 20ft G100 Nickel Duty H4/M5

Especificaciones Técnicas

Potencia Total Watts	1500	Hoist Contactor Brand	Schneider
Power Cord Length and Phase Order	3 ft / Black L1 , Red L2 and Blue L3 Green ground	Hoist UL Components	UL Listed Contactors
Capacidad de Carga	1 ton	Hoist Contactor Coil Voltage	24 V
Altura de Izaje Estandar (Customizable)	20 ft / 6 m	IEC Hoist IP Protection	IP55
Velocidad /min	25.60 ft @60Hz 6.50 mt @50Hz	Pendant Control Yes No	Included
Numero de Velocidades	1 Speed	IEC Pendant Control Protection	IP66
Voltaje	3 Phase 208~240/440~480V 50/60Hz	Pendant Control Emergency Stop	Yes
Clase de Servicio	H4/M5/2m/Class D	Pendant Control total Length	17 ft
Protección IEC Motor	IP55	Hoist Motor Power in KW	1.5
Control	Pendant Control IP66	Hoist Motor Brake Type and DC Voltage	DC99V/DC207V
Voltaje del Control	24V	Overload Protection	Overload Motor Clutch
Tipo Transmisión / Reductor	Spur gearbox	Hour Meter	Internal Working Hour Meter
Tipo de Cadena	G100 Nickel	Brake rectifiers-half-wave	PWRX-BKTF-HW
Dimensiones de la Cadena	7.1 mm	Brake rectifiers-full-wave	PWRX-BKTF-FW
Caidas de Cadena	1	Hoist Motor Insulation Grade	F
Longitud de cadena	20	Recommended Hoist Protection Circuit Breaker AMPs and Type	Type D 20A at 220V and 15A at 460V
Humedad	20%~90%	Optional Load Chain Brand & Country of Origin	FEC Japan
Temperatura	-4 ~ 104° F / -20 ~ 40° C	Reducer Lubrication Type	Oil
Normas	ASME HST-1 , ASME B30.16 , EN60204-33	Paint Specifications	Electrostatic Sprayed Plastic (ESP) Epoxy resins, Polyester Resins, Barium, Pigments
Garantía	3 Year	Load Chain weight per foot [lbs]	0.74
Hoist Contactors Amps	18A	1st Package Type	Wood Crate

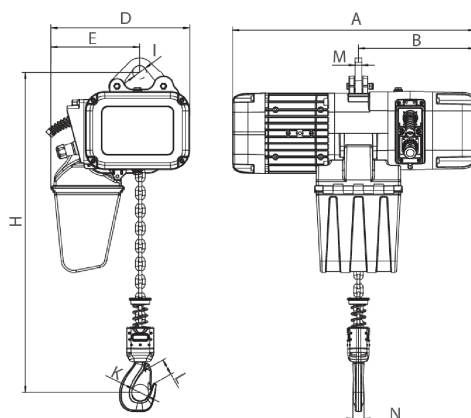

[Size list: mm]

Rated load (t)	Type	Minimum distance between hooks: H	A	B	D	E	I	M	N	K	L
1	PWRXF1-01	455	590	276	330	210	32	16	25	42	32
2	PWRXF2-01	550	590	276	330	210	38	20	35	52	42
3	PWRXF3-01	560	695	350	420	265	45	20	34	59	48
5	PWRXF5-02	675	695	350	420	307	55	28	44	60	48

Peso & Dimensiones

Peso Total 150 lbs / 69 Kg

Detalles del Empaque

H Altura Muerta 20.31

W Ancho 12.99

A Altura Total 17.91

J Boca Gancho 1.65

D Depth 23.23

Peso Total (sin cable o cadena) 113.22

Referential Images / Imágenes Referenciales
Specifications may change without notice / las especificaciones pueden cambiar sin previo aviso